

- 3 Type**
- C1 Chamfer, top
 - C2 Chamfer, bottom
 - C3 Chamfer, right
 - C4 Chamfer, left
- 5 Identification no.**
- 1 Without counter piece
 - 2 With counter piece

b ₁	s	a	d ₁	d ₂	h ₁	k ₁ min.	l ₁ ≈	l ₂	l ₃	l ₄	l ₅	l ₆	l ₇	Spring load in N ≈	
														Initial	End
13	20	6,5	34	6	10	1,5	68	10	35	1	41,5	48	26,5	14	35
20	30	10	48	9	15	2	102	15	54	1,5	60	80	40	22	70

Specification

- Guide / Counter piece**
- Steel precision casting
 - Zinc plated, blue passivated ● ZB
 - Zinc plated and powder coated
 - Black, RAL 9005, textured finish ● SW
 - Stainless steel precision casting AISI CF-8 ● NI

- Plunger pin**
- Steel, hardened
 - Zinc plated, blue passivated for ZB / SW
 - Stainless steel AISI 431, hardened for NI

- Pull ring**
- Steel precision casting
 - Zinc plated, blue passivated for ZB / SW
 - Stainless steel precision casting AISI CF-8 for NI

Pressure spring
Stainless steel AISI 316Ti
RoHS

Technical Information	Page
Application Examples	QVX
List of Indexing Plunger Types	QVX
Stainless Steel Characteristics	QVX

Indexing plungers GN 724.6 have a plunger pin with square cross-section, a latching surface on one side and a chamfer on the other. When the object to be secured moves towards the chamfer, the plunger pin is pushed back into the guide, allowing grooves and edges to pass over the pin. The plunger pin engages automatically in the direction of the latching surface. The latching can be released by pulling the pull ring by hand or with a cable or pull rod using a hook.

The types with rest position are used when the plunger pin should temporarily not protrude. For this purpose, the pull ring is turned sideways after the plunger pin has been retracted. The ring is held in this position by the catch recess at the top of the guide.

The dimensional tolerances between the pin and the guide have been chosen to ensure functional reliability even in roughly dimensioned applications or in the event of soiling.

For fastening, slotted or hex mounting holes allow the use of socket cap screws ISO 4762 and hex head screws or nuts according to DIN 931 or DIN 934.

How to order

1	b ₁
2	s
3	Type
4	Finish (Material)
5	Identification no.

GN 724.6-13-20-C2-ZB-1

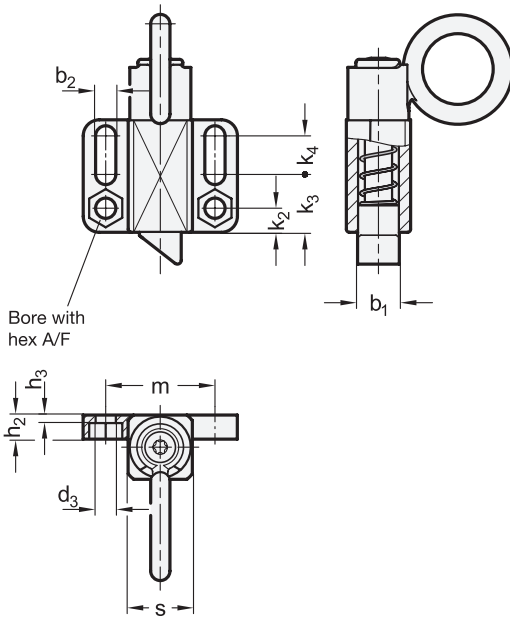

Counter piece identification no. 2

Type C1 / C2

Type C3 / C4

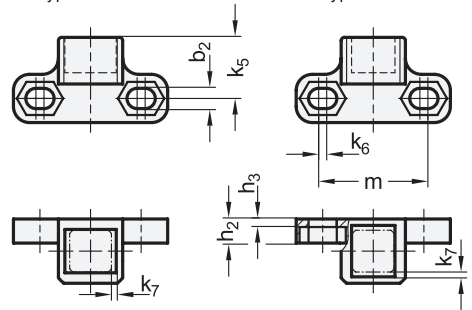

b₁	s	b₂ +0,3	d₃ +0,2	h₂	h₃	k₂	k₃	k₄	k₅	k₆	k₇	m	A/F
13	20	6,5	6,1	7,5	1,5	7,5	18	12	19	2,5	1,5	34	10
20	30	10	10,1	14	5	14	34	10	27,5	3	2	55	17

Application Examples

