

Mounting holes - outer slide

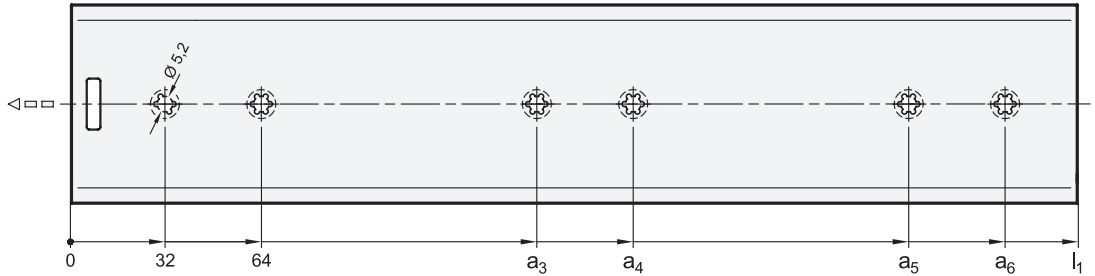

l_1	a_3	a_4	a_5	a_6
400	288	320	-	-
450	288	320	-	-
500	352	384	-	-
550	352	384	-	-
600	448	480	-	-
700	448	480	-	-
800	384	416	672	704

Mounting holes - inner slide

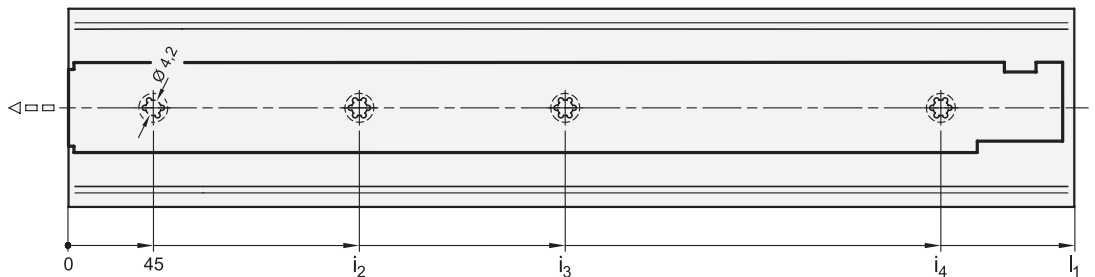

l_1	i_2	i_3	i_4
400	173	333	-
450	205	397	-
500	237	461	-
550	269	493	-
600	173	301	557
700	173	333	653
800	205	397	749

Fastening screws

For the said loading forces F_S to be absorbed reliably in the surrounding structure, all available countersunk holes of the outer and inner slide must be used. Failure to use fastening screws reduces the specified load capacity accordingly. The following screws can be used for mounting:

Designation - standard		Outer slide	Inner slide
Countersunk screw, Phillips	DIN 965	M 5	M 4
Countersunk screw, Phillips	DIN 7997	Size 5	Size 4 / 4,5

Rubber stop

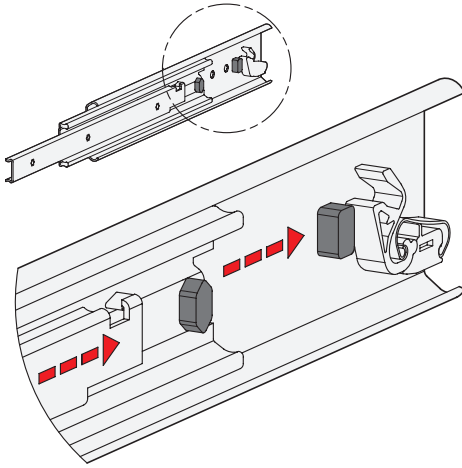

The rubber stops of type B dampen the impact of the slide in the respective end position. This feature minimizes noise development and increases the lifespan. Attached to the slides in a partially concealed, partially visible manner, the stops meet each of the requirements in regard to shape, material, and hardness.

If larger static or dynamic loads occur in the direction of extension, they should be absorbed by external stop elements.

Self-retracting mechanism

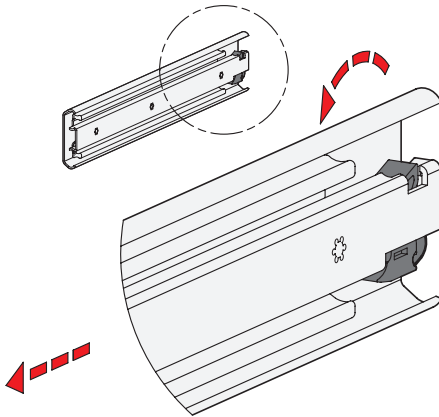

Telescopic slides GN 1432 have an integrated self-retracting mechanism, which improves considerably the ease of use when closing the extensions.

The slides are retracted and held in the back end position automatically by means of a retraction mechanism on the last 22 mm of stroke with a force of approximately 30 newtons for each slide pair. This force has to be overcome accordingly on opening the extension.

The self-retracting mechanism is also designed in such a way that it uncouples and will not be damaged when the extension is opened or closed in a jerky manner or too quickly. On the following stroke, the self-retracting mechanism clicks back into place automatically, ensuring that the function remains intact.

