

## Mounting holes - outer slide

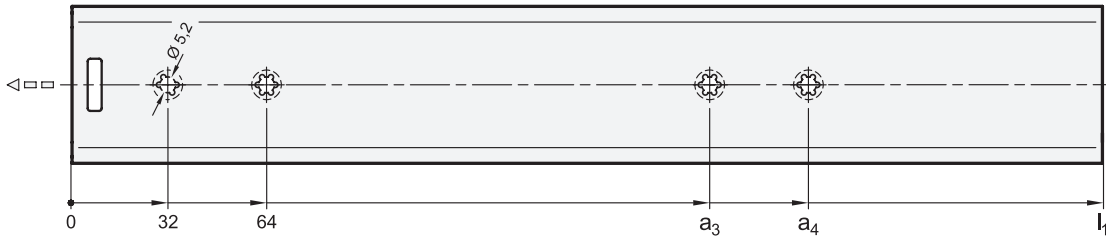

$l_1$	$a_3$	$a_4$
350	192	224
400	224	256
450	288	320
500	320	352
550	352	384
600	416	448
700	448	480

## Mounting holes - inner slide

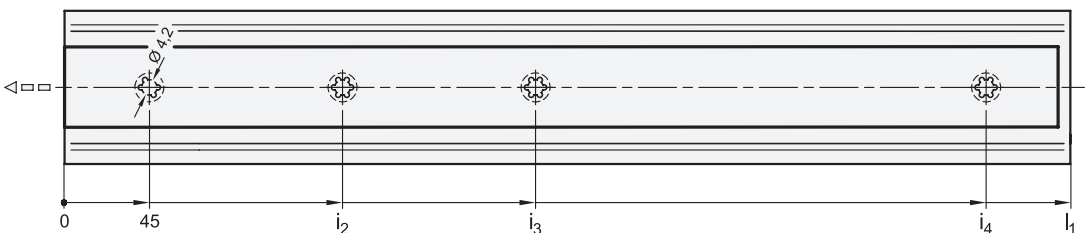

$l_1$	$i_2$	$i_3$	$i_4$
350	173	301	-
400	173	333	-
450	205	397	-
500	237	461	-
550	269	493	-
600	173	301	562
700	173	333	653

## Fastening screws

For the said loading forces  $F_S$  to be absorbed reliably in the surrounding structure, all available countersunk holes of the outer and inner slide must be used. Failure to use fastening screws reduces the specified load capacity accordingly. The following screws can be used for mounting:

Designation - standard	Outer slide	Inner slide
Hexagon socket countersunk head screw DIN 7991	M 5	M 4
Countersunk screw, Phillips DIN 965	M 5	M 4
Countersunk screw, Phillips DIN 7997	Size 5	Size 4 / 4,5

### Rubber stop

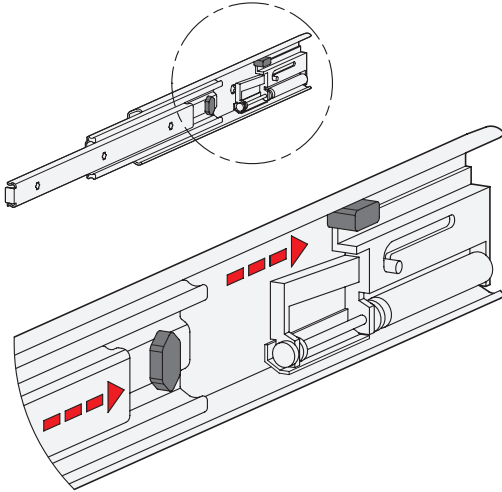

The rubber stops of type B dampen the impact of the slide in the respective end position. This feature minimizes noise development and increases the lifespan. Attached to the slides in a partially concealed, partially visible manner, the stops meet each of the requirements in regard to shape, material, and hardness.

If larger static or dynamic loads occur in the direction of extension, they should be absorbed by external stop elements.

### Self-retracting mechanism, dampened

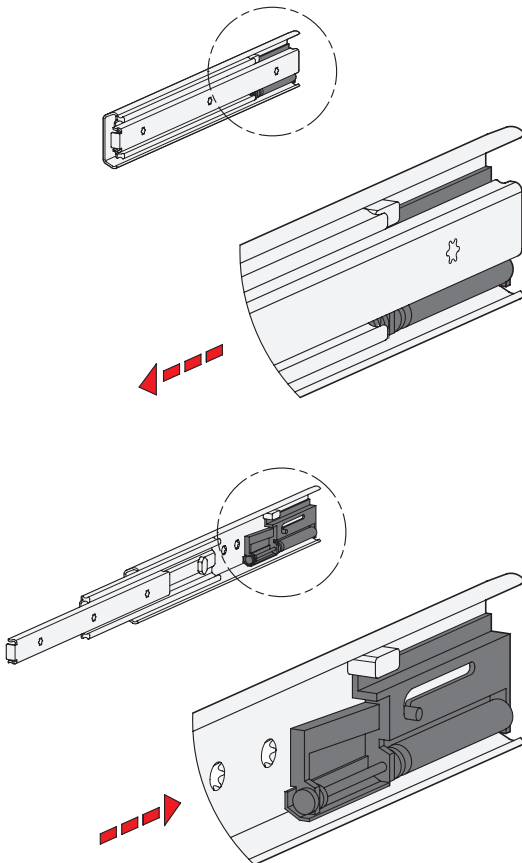

Telescopic slides GN 1424 have a dampened self-retracting mechanism, which is also called “soft-close”. The dampened self-retracting mechanism is divided into two main functions and offers the best possible ease of use on closing the extension.

The self-retracting mechanism takes over the automatic retraction of the slides on the last 40 mm of stroke in the back stop position, where the slides are held in place accordingly. The retraction force is about 35 newtons per slide pair. Also, the dampening mechanism slows down to a considerably reduced speed the closing movement on the said stroke. An extremely smooth and gentle closing movement is achieved. This retraction force has to be overcome accordingly on opening the extension.

The dampened self-retracting mechanism is designed for loads weighing up to 75 kg based on 60,000 cycles (LGA standard). Proper use, including the reduction of the stroke speed to no more than 0.15 m/s on reaching the retraction mechanism, as well as compliance with the load values are required.

3.1  
3.2  
3.3  
3.4  
3.5  
3.6  
3.7  
3.8  
3.9

