

- 3 Type**
- A** With 2 key rings
  - B** With mounting tab and key ring
  - C** With 2 mounting tabs
  - D** With 2 loops
  - E** With mounting tab and loop

**1**

Length l				d <sub>1</sub>	d <sub>2</sub>	d <sub>3</sub>		Static load in N ≈	
						BL	TR / SW	With key ring	Without key ring
150	200	320	500	14 *	1	1,6	3	50	1800
150	200	320	500	18 **	1,3	1,6	3	90	1800
150	200	320	500	24 ***	1,5	1,6	3	100	1800
150	200	320	500	30	1,8	1,6	3	120	1800

**2**

d <sub>1</sub>	Key rings (Type A and B) suitable for ball lock pins and locking pins with axial lock with pin diameter								
	GN 113.1 GN 113.3 GN 113.4 GN 113.7 GN 113.8 GN 113.9 GN 113.10	GN 113.5 GN 113.6	GN 113.11 GN 113.12	GN 114.2 GN 114.3 GN 114.6	GN 124.1 GN 124.2	GN 124.3	GN 214.2 GN 214.3 GN 214.6	GN 314	
14	5 / 6 / 8	alle	5 / 6 / 8 / 10	alle	alle	8 / 10	6 / 8	-	
18	10 / 12 / 16 / 20 / 25	-	12 / 16	-	-	10 / 12	10 / 12 / 16 / 20 / 25	8 / 10 / 12	
24	-	-	20 / 25	-	-	-	-	16 / 20	
30	-	-	-	-	-	-	-	-	

Application examples

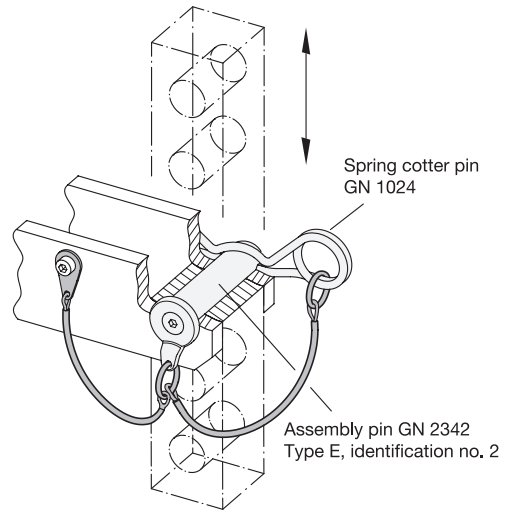
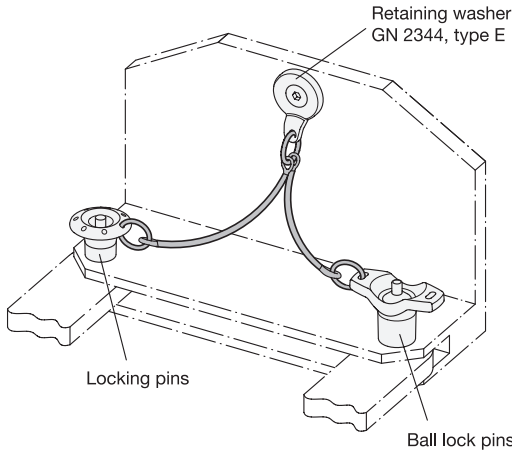

Specification



- Retaining cable  
Stainless steel AISI 304
  - Plain finish ○ BL
  - Plastic coated (PVC) ○ TR
  - Transparent ● SW
  - Black
- Mounting tab  
Stainless steel AISI 304
  - Plain (for BL / TR)
  - Zinc plated, black passivated (for SW)
- Key ring  
Stainless steel AISI 301
  - Plain, ground (for BL / TR)
  - Zinc plated, black passivated (for SW)
- Press sleeves  
Aluminum
  - Plain (for BL / TR)
  - Black anodized (for SW)
- [Stainless Steel Characteristics](#) → Page 2166
- [RoHS](#)

Accessory

- Key Rings GN 111.3 → Page 1178

Information

Retaining cables GN 111.2 are available in 5 different types and can therefore be used in a wide range of applications, e.g. for loss protection or as connecting and fastening cables.

The coating of versions TR and SW protects adjacent parts from chafing or other damage. The smooth surface is also pleasant to the touch. The black design is visually discreet and is also used in situations where the reflections on the surface are to be minimized.

On delivery the key rings are already mounted on the retaining cable. With type A, both rings have the same diameter  $d_1$ .

The orientation of the cable loops and mounting tabs may differ from what is depicted in the drawing. The load values given in the table are non-binding guide values and rule out any liability.

see also...

- [Retaining Cables GN 111.8 \(Stainless Steel\)](#) → Page XYZ
- [Ball Chains GN 111](#) → Page 1174
- [Ball Chains GN 111.5 \(Stainless Steel\)](#) → Page 1174
- [Spiral Retaining Cables GN 111.4](#) → Page 1175

How to order (Type C, D and E)	1 Length l
 <b>GN 111.2-150-E-TR</b>	3 Type
	4 Color

How to order (Type A and B)	1 Length l
 <b>GN 111.2-500-30-A-SW</b>	2 $d_1$
	3 Type
	4 Color

